





APRILIA ITALY

1800 mq
Headquarters



Made in
Italy



Qualified
Staff



Quality
Control



PASSION FOR OUR WORK **SUPPORT FOR YOUR IDEAS**

La STD progetta e realizza equipment per il processo farmaceutico e biotecnologico in accordo con le norme internazionali di riferimento. La nostra mission è progettare e realizzare soluzioni innovative a misura del cliente.

STD designs and manufactures equipment for pharmaceutical and biotechnology process in according to international standards. Our mission is to design and implement innovative solutions tailored to the customer.

SERVIZI **SERVICES**

FERMENTATION

WATER TREATMENT

CLEANING & WASHER

STAINLESS STEEL CARPENTRY

PRODUCTION EQUIPMENT

La nostra produzione di **FERMENTATORI** è prevalentemente indirizzata al processo farmaceutico e biotecnologico. Nella fase di progettazione si tiene conto delle differenti tipologie di mix e delle caratteristiche dei prodotti, allo scopo di proporre una fornitura mirata alle esigenze produttive. Sono fornibili in capacità dai 10lt ai 500lt termostatati e coibentati, in accordo alle normative ISPE, PED e CE.

Our **FERMENTER** production is mainly used for pharmaceutical and biotechnology process. During the design phase, STD offers customized supplies based on the different types of product to be mixed and production needs. STD can supply fermenter from 10lt to 500lt thermostated and insulated in accordance with ISPE, PED and CE.



FERMENTAZIONE

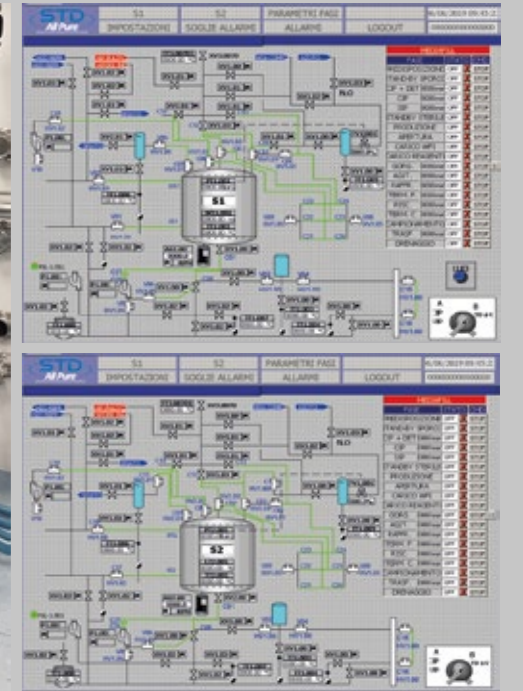

Progettiamo e realizziamo “chiavi in mano” **SALE PREPARAZIONI** complete di piping, preparatori e automazione con interfaccia PLC, DCS e SCADA in accordo alle normative cGMP, FDA e ASME BPE. Il nostro servizio comprende tutte le fasi lavorative, dalla progettazione alla validazione (DQ IQ OQ e PQ).

We design and manufacture turnkey **PREPARATION ROOMS** complete with everything necessary, starting from piping, mixer and tanks up to the automation control system based on PLC, DCS and Scada technologies in accordance with cGMP, FDA and ASME BPE standards. STD services cover all phases of the work, from design to validation (DQ IQ OQ and PQ).

FERMENTATION

Progettiamo e realizziamo impianti chiavi in mano per la produzione, stoccaggio e distribuzione di acqua distillata **WFI** e acqua purificata **PW**, circuiti di distribuzione **FLUIDI PURI** quali Vapore pulito, Aria compressa e Azoto.
Completi di sistema di controllo e automazione specifici per l'industria farmaceutica, chimica e alimentare, secondo le normative ISPE, FDA, cGMP, ASME BPE e CFR 21.



We design and manufacture turnkey plants for production, storage and distribution of distilled water **WFI** and purified water **PW**, distribution system for **PURE FLUIDS** such as clean steam, compressed air and nitrogen.
Complete with automation control systems for the pharmaceutical, chemical and food industries in accordance with ISPE, FDA, cGMP, ASME BPE and CFR 21 regulations.



TRATTAMENTO ACQUE

WATER TREATMENT

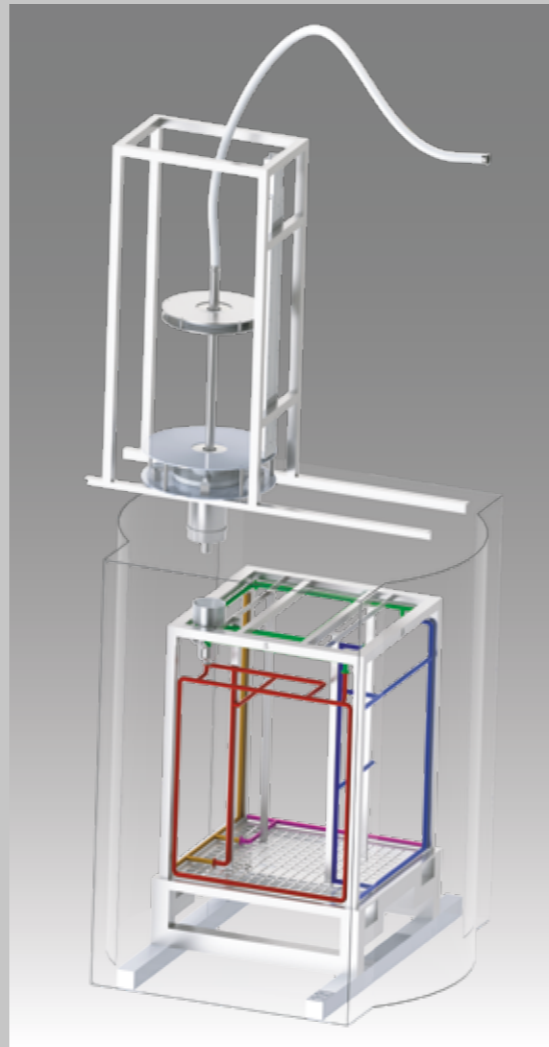
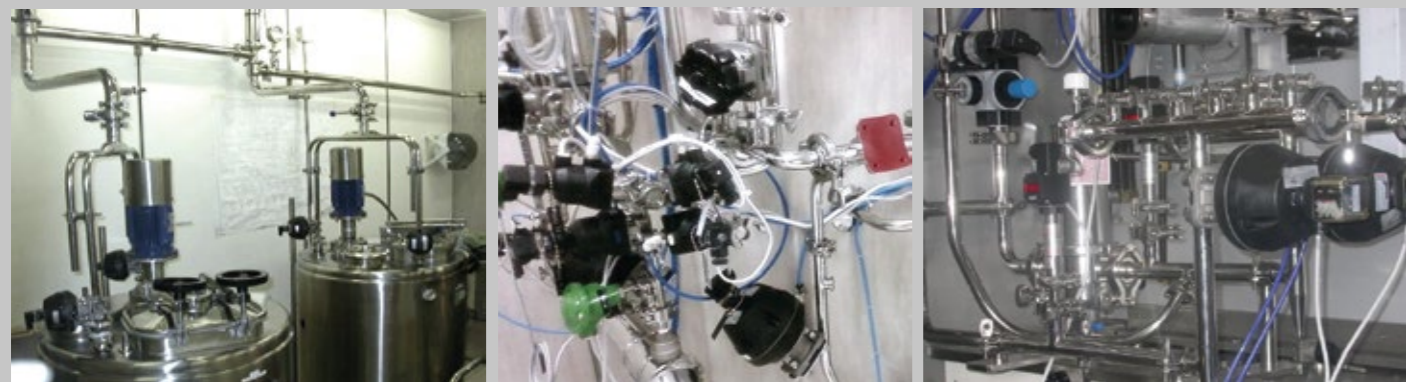

Progettiamo e realizziamo impianti CIP/SIP, stazioni di lavaggio automatizzati per la pulizia e decontaminazione delle attrezzature di produzione, carrelli LAF autoalimentati.

We design and manufacture CIP / SIP systems, automated washing stations for cleaning and decontamination of production facilities, self-powered LAF trolleys.

PULIZIA E LAVAGGIO

CLEANING & WASHER

Completa le nostre lavorazioni la progettazione e la realizzazione di **CARPENTERIE** in Acciaio inox, per le quali abbiamo conseguito le certificazioni EN1090 per la costruzione di strutture metalliche e la UNI3839 per il processo di saldatura.

Our work also includes the design and manufacture of stainless steel **CARPENTERIES**.
STD is EN1090 (for the construction of metal structures) and UNI3839 (welding processes) certified.

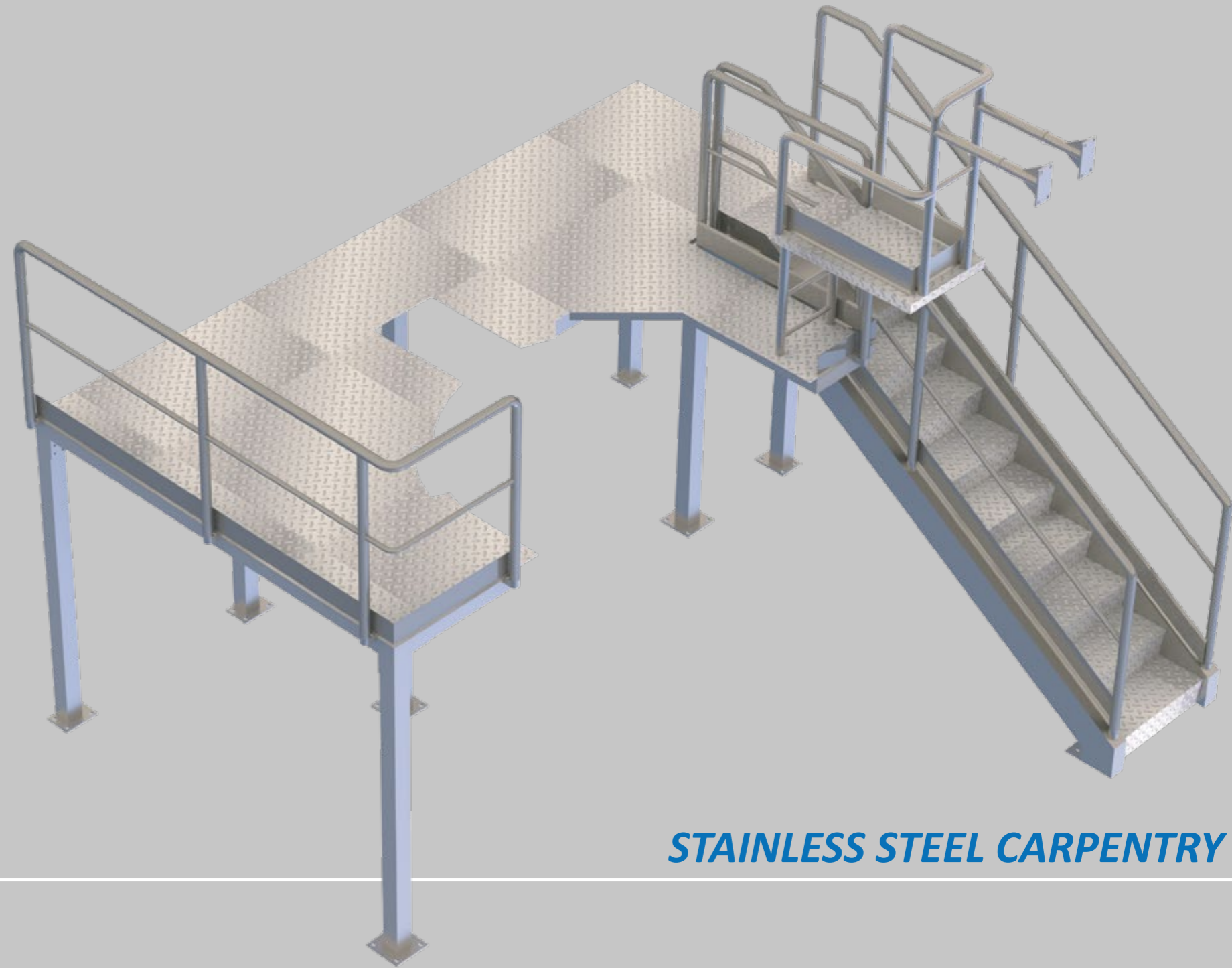
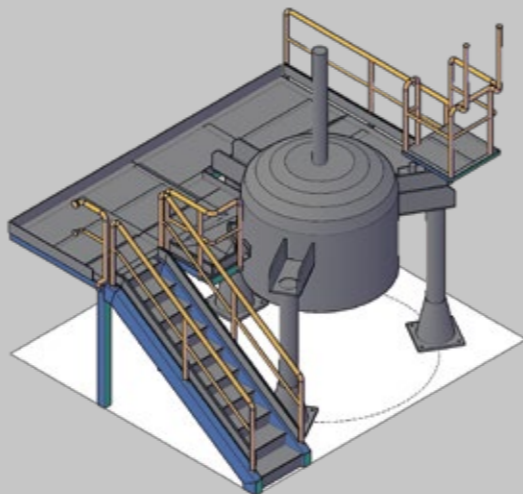

CARPENTERIE IN ACCIAIO INOX

STAINLESS STEEL CARPENTRY

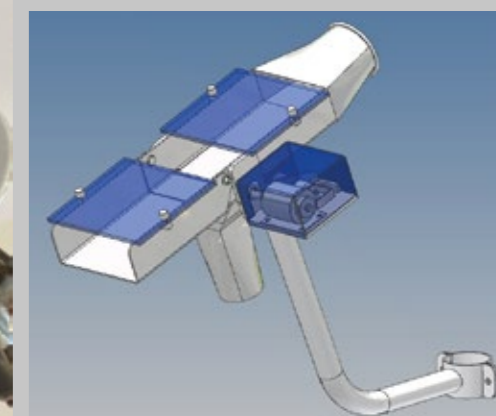
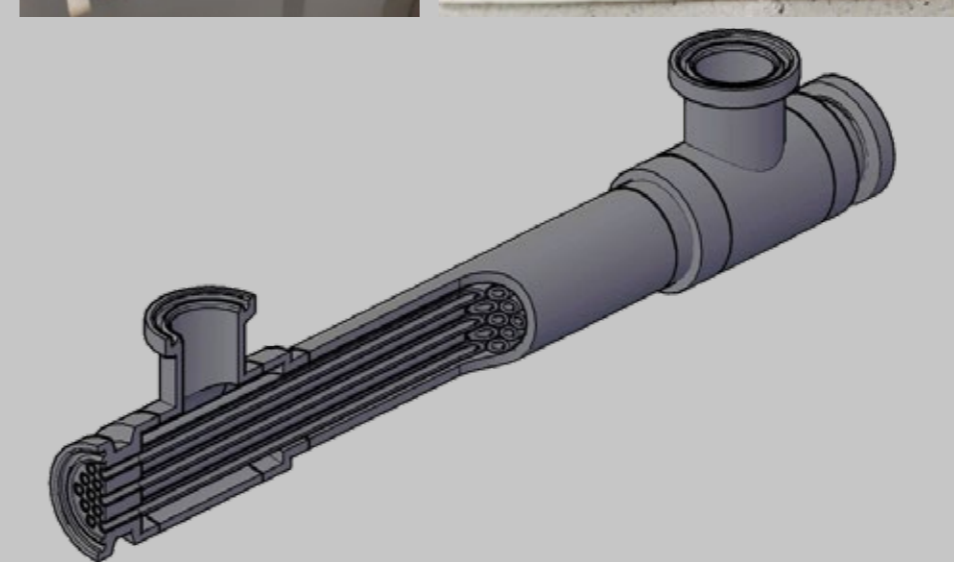
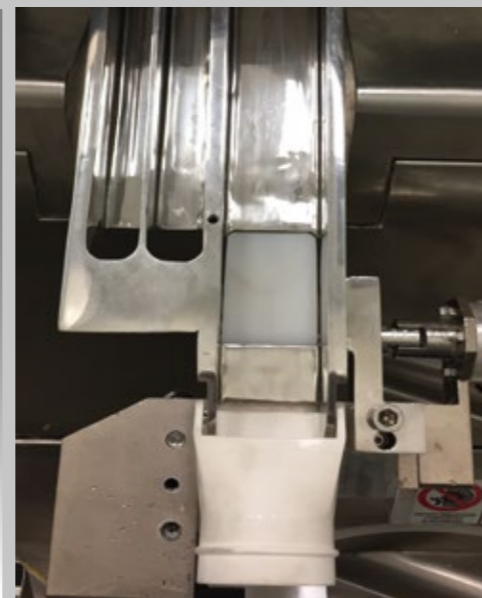
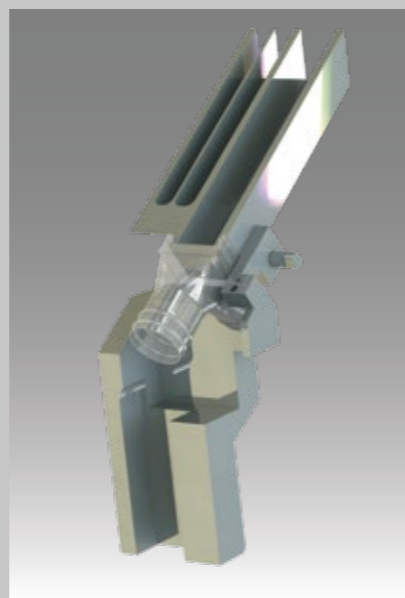
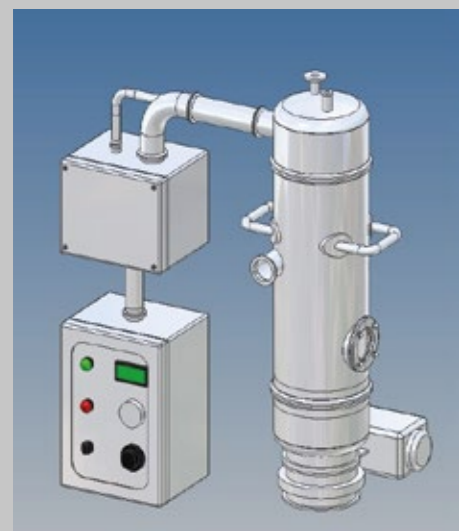
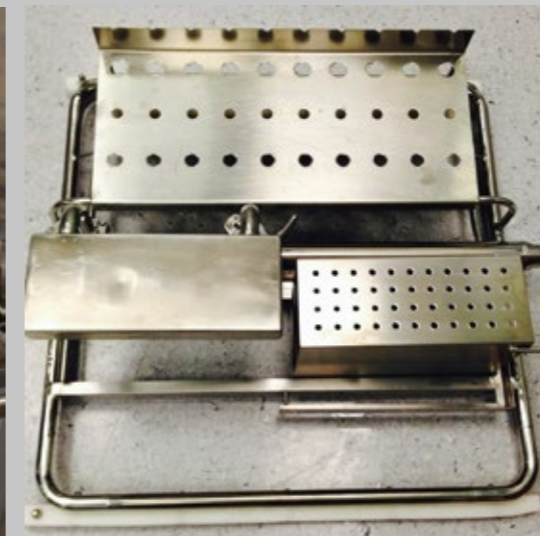

ACCESSORI DI PRODUZIONE

PRODUCTION EQUIPMENT



www.std-allpure.com
std@pec.std-allpure.com
info@std-allpure.com
T +39 06 92703863